



JAYCO VENT VALVE MAINTENANCE

BEFORE PROCEEDING WITH MAINTENANCE ON THE VENT VALVE, CONSULT YOUR COMPANY'S SAFETY AND OPERATIONS MANUALS CONCERNING THE DANGERS INVOLVED WITH WORKING ON A VENT VALVE AND TANK BATTERY. **USE EXTREME CAUTION!**

OBSERVE...

- THE OPERATION OF THE VENT VALVE, IS IT HOLDING PRESSURE?
- DOES IT RELIEVE PRESSURE AS SET?

CLEAN...

- KEEP THE GASKETS AND MOVING PARTS FREE OF DIRT AND RESIDUE
- INLINE VALVES HAVE A DRAIN PLUG IN THE BODY TO EMPTY FLUID IF NECESSARY, DO SO IN COMPLIANCE WITH ENVIRONMENTAL REGULATIONS

INSPECT...

- THE GASKETS FOR WEAR, CRACKING AND SWELLING; REPLACE AS NEEDED
- THE ALUMINUM SEATS INSIDE THE VALVE AND PLUNGER FOR DAMAGE AND REPAIR OR REPLACE AS NEEDED
- SOME STACK VALVES MAY HAVE AN EXTERNAL LEVER, ENSURE LEVER HAS PROPER MOVEMENT WITH THE INTERNAL PRESSURE/VACUUM VALVE

REPAIR OR REPLACE...

- REPLACE GASKETS WITH JAYCO GASKETS SETS ONLY
- IF H₂S IS PRESENT OR OTHER CHEMICALS THAT REACT WITH THE CURRENT GASKETS, REPLACE WITH VITON® GASKET SETS
- IF AMBIENT TEMPERATURE IS ABOVE 200 DEGREES F, REPLACE GASKETS WITH VITON®
- WHEN CLOSING THE CAPS ON INLINE VALVES, TIGHTEN THE TWO NUTS EVENLY FOR A GOOD SEAL

ORDER JAYCO PARTS FROM YOUR LOCAL OILFIELD SUPPLY COMPANY OR TANK MANUFACTURER

THE FOLLOWING PAGES WILL ASSIST YOUR SELECTION OF REPLACEMENT PARTS

**** KEEP THE VENT VALVE CLEAN AND INSPECT ON A REGULAR BASIS ****

PAGE 1	INLINE VENT VALVE PARTS LIST FOR JAYCO
PAGE 2	STACK VENT VALVE PARTS LIST FOR JAYCO
PAGE 3	PRESSURE SETTINGS ON JAYCO VENT VALVES

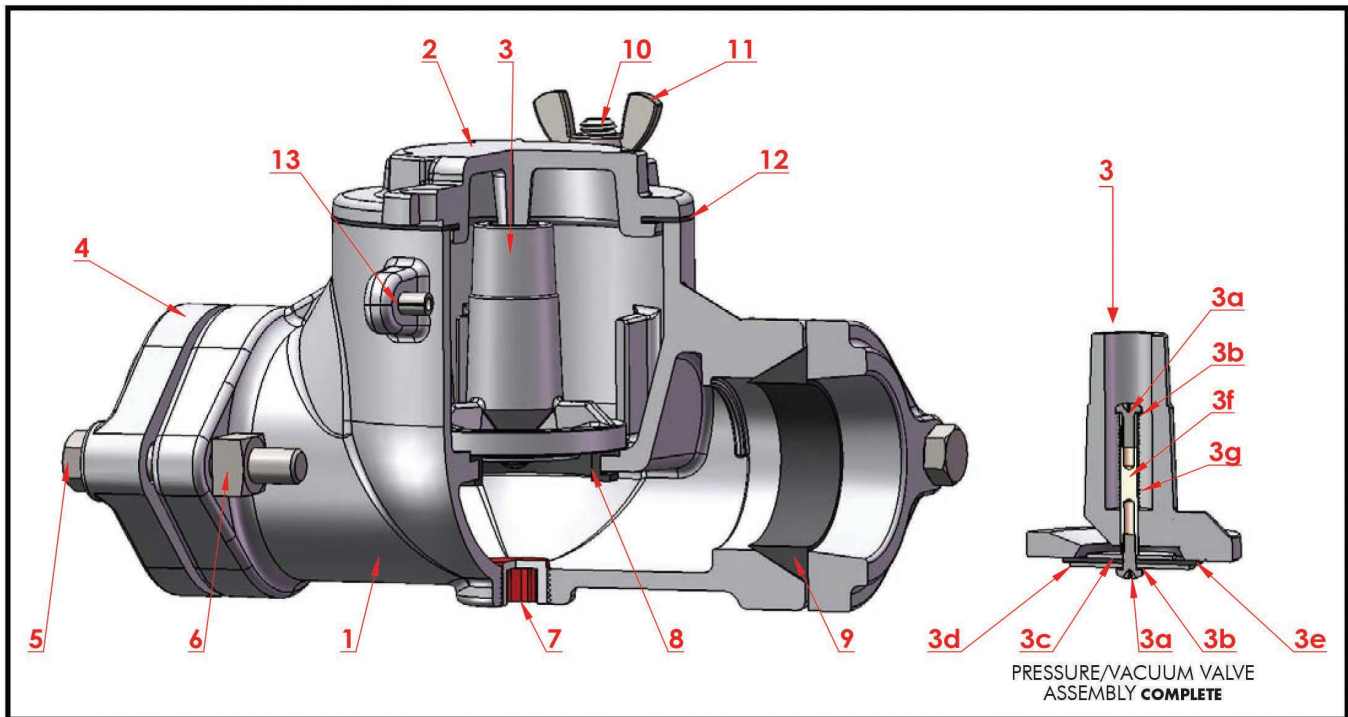

	JV 101 - 2"	JV 301 - 3"	JV 500 - 4"
BODY LENGTH W/O FLANGES HEIGHT	8.25"L 7"H	10"L 8"H	10.5"L 10.5"H
1. VALVE BODY - ALUMINUM			
2. VALVE BODY CAP - ALUMINUM	JV0121	JV0321A	JV0520
3. PRESSURE/VACUUM VALVE ASSEMBLY <i>COMPLETE</i>	JV0110	JV0311	JV0510
3a. PAN HEAD SCREW - ZINC PLATED	JV0156	JV0156	JV0156
3b. INTERNAL LOCK WASHER - ZINC PLATED	JV0155	JV0155	JV0155
3c. WASHER (SMALL) - ALUMINUM	JV0148	JV0150	JV0348
3d. WASHER (LARGE) - ALUMINUM	JV0150	JV0348	JV0350
** 3e. VACUUM GASKET - BUNA N	JV0152	JV0353	JV0352
VACUUM GASKET (SOUR SERVICE) - VITON®	JV0153	JV0354	JV0553
3f. VACUUM VALVE STEM - BRASS	JV0146	JV0146	JV0446
** 3g. VACUUM SPRING - STAINLESS STEEL	JV0144	JV0144	JV0444
4. SLIP-ON FLANGE - ALUMINUM	JV0136	JV0337	JV0436
5. SLIP-ON FLANGE BOLT - ZINC PLATED	JV0181	JV0181	JV0181
6. SLIP-ON FLANGE NUT - ZINC PLATED	JV0180	JV0180	JV0180
7. DRAIN PLUG - RED PLASTIC	JV0158	JV0158	JV0158
** 8. PRESSURE O-RING GASKET - VITON® <i>CURRENT VALVES</i>	JV0141	JV0341	JV0440
PRESSURE CLIP-IN GASKET - BUNA N <i>ORIGINAL VALVES</i>	JV0142	JV0343	JV0342
9. SLIP-ON FLANGE GASKET - BUNA N	JV0134	JV0335	JV0434
10. EYE BOLT - ALUMINUM	JV0126	JV0126	JV0126
11. HEX NUT - ZINC PLATED <i>REPLACES WING NUT</i>	JV0137	JV0137	JV0137
** 12. CAP GASKET - BUNA N	JV0125	JV0323	JV0522
CAP GASKET (SOUR SERVICE) - VITON®	JV0127	JV0325	JV0523
13. GROOVE PIN - ZINC PLATED	JV0131	JV0130	JV0130
PRESSURE WEIGHT 1.0 oz - BRONZE	JV0260B	JV0360B	JV0460B
PRESSURE WEIGHT 0.5 oz - BRONZE	JV0260A	JV0360A	JV0460A

HIGHER WEIGHT SETTINGS VISIT: WWW.JAYCO.ORG/PRODUCTS-CATEGORY/JAYCO-VENT-VALVE/

IN KEEPING WITH, AND FOR THE PURPOSE OF PRODUCT IMPROVEMENT, JAYCO RESERVES THE RIGHT TO MAKE DESIGN CHANGES WITHOUT PRIOR NOTICE.

** REPAIR KIT

VITON® IS A REGISTERED TRADEMARK OF DUPONT DOW ELASTOMERS

BULLETIN NUMBER 1015 23

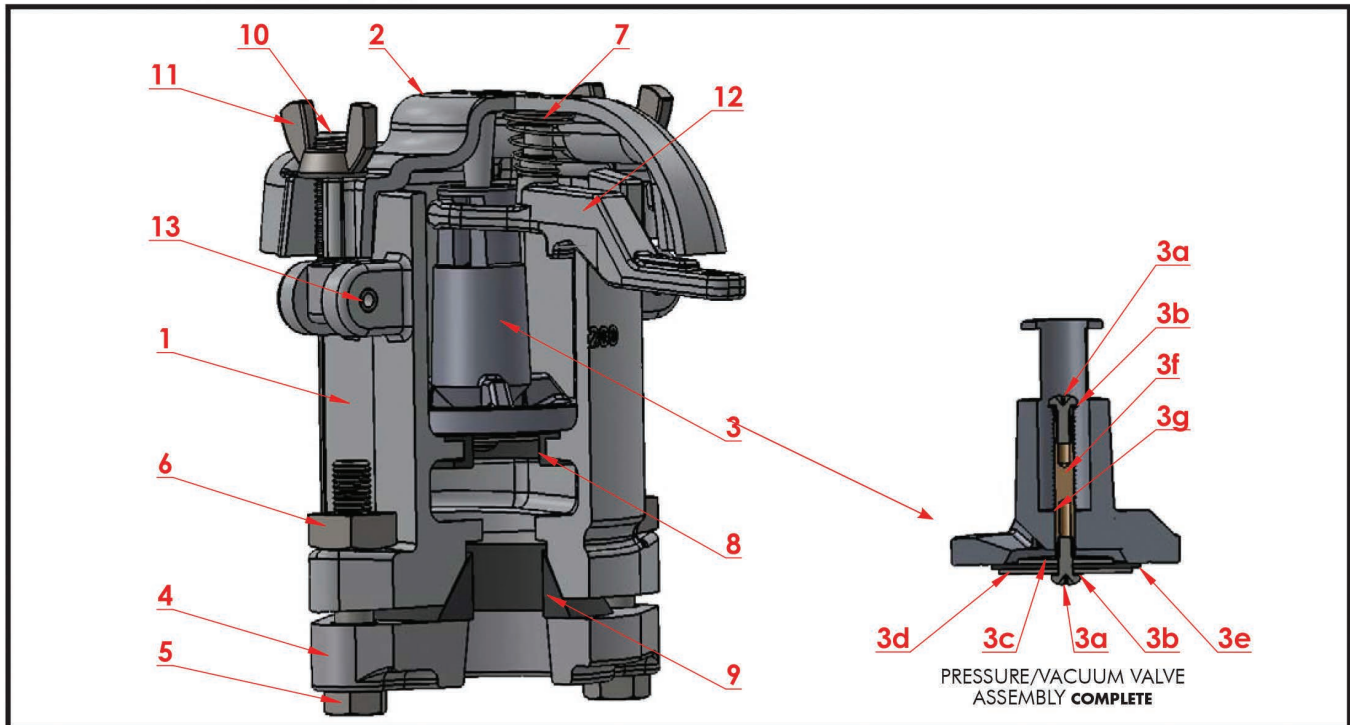

	JV 200 - 2"	JV 401 - 3"	JV 600 - 4"
1. VALVE BODY - ALUMINUM			
2. VALVE BODY CAP - ALUMINUM	JV0220	JV0421	JV0420
3. PRESSURE/VACUUM VALVE ASSEMBLY <i>COMPLETE</i>	JV0110	JV0311	JV0510
3a. PAN HEAD SCREW - ZINC PLATED	JV0156	JV0156	JV0156
3b. INTERNAL LOCK WASHER - ZINC PLATED	JV0155	JV0155	JV0155
3c. WASHER (SMALL) - ALUMINUM	JV0148	JV0150	JV0348
3d. WASHER (LARGE) - ALUMINUM	JV0150	JV0348	JV0350
** 3e. VACUUM GASKET - BUNA N	JV0152	JV0353	JV0352
VACUUM GASKET (SOUR SERVICE) - VITON®	JV0153	JV0354	JV0553
3f. VACUUM VALVE STEM - BRASS	JV0146	JV0146	JV0446
** 3g. VACUUM SPRING - STAINLESS STEEL	JV0144	JV0144	JV0444
4. SLIP-ON FLANGE - ALUMINUM	JV0136	JV0337	JV0436
5. SLIP-ON FLANGE BOLT - ZINC PLATED	JV0181	JV0181	JV0181
6. SLIP-ON FLANGE NUT - ZINC PLATED	JV0180	JV0180	JV0180
7. CONICAL LEVER SPRING - ZINC PLATED <i>OPTIONAL</i>	JV0262	JV0262	JV0262
** 8. PRESSURE O-RING GASKET - VITON® <i>CURRENT VALVES</i>	JV0141	JV0341	JV0440
PRESSURE CLIP-IN GASKET - BUNA N <i>ORIGINAL VALVES</i>	JV0142	JV0343	JV0342
9. SLIP-ON FLANGE GASKET - BUNA N	JV0134	JV0335	JV0434
10. EYE BOLT - ALUMINUM	JV0126	JV0126	JV0126
11. HEX NUT - ZINC PLATED <i>REPLACES WING NUT</i>	JV0137	JV0137	JV0137
12. LEVER - ALUMINUM <i>OPTIONAL</i>	JV0230	JV0431	JV0431
13. GROOVE PIN - ZINC PLATED	JV0131	JV0130	JV0130
PRESSURE WEIGHT 1.0 oz - BRONZE	JV0260B	JV0360B	JV0460B
PRESSURE WEIGHT 0.5 oz - BRONZE	JV0260A	JV0360A	JV0460A
LEVER ROLL PIN - ZINC PLATED <i>DISCONTINUED</i>	JV0264	JV0264	JV0264

HIGHER WEIGHT SETTINGS VISIT: WWW.JAYCO.ORG/PRODUCTS-CATEGORY/JAYCO-VENT-VALVE/

IN KEEPING WITH, AND FOR THE PURPOSE OF PRODUCT IMPROVEMENT, JAYCO RESERVES THE RIGHT TO MAKE DESIGN CHANGES WITHOUT PRIOR NOTICE.

** REPAIR KIT

VITON® IS A REGISTERED TRADEMARK OF DUPONT DOW ELASTOMERS

BULLETIN NUMBER 1007 23

JAYCO VENT VALVES ARE SHIPPED FROM THE FACTORY SET AT 1.3 OZ/INCH² PRESSURE FOR 2" AND 3" VALVES WHILE 4" VALVES ARE SET AT 1.5 OZ/INCH², UNLESS OTHERWISE SPECIFIED. THE VACUUM SETTING OF 0.4 OZ/INCH² IS SPRING OPERATED AND NOT AFFECTED BY CHANGING THE PRESSURE SETTING.

TO INCREASE THE PRESSURE SETTING OF THE VALVE, WEIGHTS CAN BE ADDED TO THE INTERNAL PLUNGER ASSEMBLY. FOR HIGHER PRESSURE SETTINGS THE ALUMINUM PLUNGER MUST BE REPLACED BY A BULLET PLUNGER.



SMALL INCREASE

ADD WEIGHT(S) IN 0.5 OZ/INCH² OR 1 OZ/INCH² INCREMENTS TO THE PLUNGER ASSEMBLY TO GAIN DESIRED PRESSURE SETTING. THIS IS DONE WITH BRONZE WASHERS CALLED WEIGHTS. EACH VALVE HAS A MAXIMUM AMOUNT OF WASHERS THAT CAN BE ADDED.

PICTURED 1 oz WEIGHT • FLEXIBILITY

MEDIUM INCREASE

WHEN ADDING MORE THAN 1 OZ/INCH² A CUSTOM BRONZE WEIGHT CAN BE ADDED TO THE PLUNGER ASSEMBLY TO GAIN THE DESIRED PRESSURE SETTING. I.E. ADD A 2.5 OZ/INCH² WEIGHT TO A STANDARD PLUNGER ASSEMBLY TO HAVE A PRESSURE SETTING OF 4 OZ/INCH², (1.5 + 2.5 = 4.0).

PICTURED 2.5 oz WEIGHT • ECONOMICAL



LARGE INCREASE

FOR HIGHER PRESSURE SETTINGS THE PLUNGER ASSEMBLY MUST BE SWITCHED OUT WITH A CUSTOM "BULLET PLUNGER ASSEMBLY." THESE LARGE BRONZE WEIGHTS HAVE THE VACUUM BREAKER BUILT INTO THEM. THESE ARE SOLD BY THEIR TOTAL PRESSURE SETTING AND NOT THEIR ADDITIONAL INCREASE LIKE THE WEIGHTS.

PICTURED 16 oz BULLET PLUNGER



FOR MORE INFORMATION AND PART NUMBERS PLEASE VISIT THE VENT VALVE PAGE AT JAYCO.ORG. THE PRESSURE SETTING TAB HAS INFORMATION ON MAXIMUM AMOUNT OF WEIGHTS THAT CAN BE ADDED TO EACH VALVE AND WHEN A "BULLET PLUNGER" MUST BE USED.

REMEMBER THAT INCREASING THE PRESSURE SETTING ON THE VENT VALVE WILL DELAY THE PRESSURE RELIEF. MAKE SURE THAT THE CHANGES MADE WILL WORK WITHIN THE CONFINES OF THE INSTALLATION. PLEASE CALL IF YOU HAVE QUESTIONS ABOUT THIS DOCUMENT.